

HVS-4000

HV Slip Ring

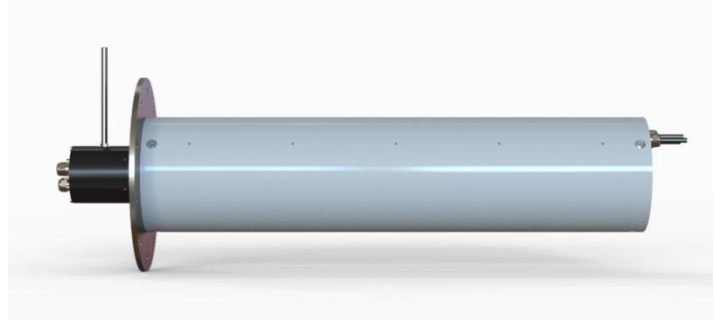

Key features

- Contactless rotary High Voltage, High pulsed current electrical contacts.
- Designed for continuous operations with aae's CSP-Nv and CSP-SNv plus Dura-Spark seismic source range.
- 3 independent HV contacts rated to 6KV isolation.
- IP69 O-ring sealed inert Delrin chassis for safety.
- Option for cable drum exits on outer or internal face.
- Supplied with sealed HV Junction boxes for complete user contact free operations. Outer drum junction box is integrated to the CSP interlock circuitry for safety.
- Mounting plates available for outer or inner side with custom options available.

HVS-4000 Overview

The HVS-4000 High Voltage slip ring assembly has been developed to provide a rotary connection solution for survey operations using CSP- Nv (or CSP- SNv) plus Dura-Spark sound sources.

The HVS-4000 provides 3 HV rated and isolated rotary contacts. The chassis has been designed for the harsh conditions associated with offshore geophysical survey operations. The HVS-4000 chassis materials are selected for intrinsic safety and sealed with O-rings to ensure a min of IP69 rating.

The HVS-4000 is compatible with all CSP and Dura-Spark systems supplied by applied acoustics.

Mechanical interface to user winch is flexible and bespoke options are available. The mounting plate can be adapted and fitted internal or external. The OD of the main body can be expanded with packers as required.

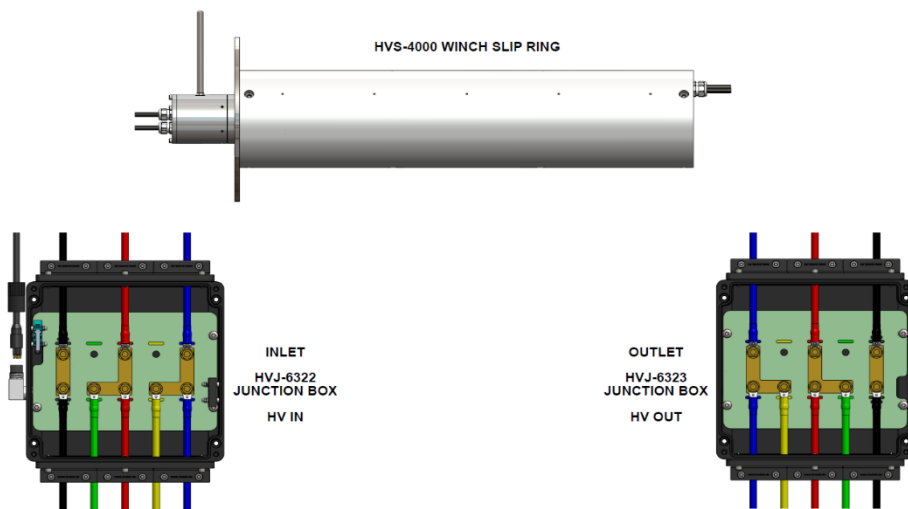

Technical Specification

PHYSICAL

Diameter	Ø 220mm
Length (internal)	831.0mm
Length (overall)	920.0mm
Mounting plate	Ø 370mm. Standard, options available.
Weight	33.5Kg with single mount plate
RPM	60 nominal
Temperature	-20 to 70°C
Chassis Material	Delrin

ELECTRICAL CONTACT

Operating Voltage	5000V
Operating Current	10,000A peak, 200uS Pulse Width
Resistance	<0.02mΩ
RPM	100 max
Contact Isolation	6KV DC Routine test voltage.

INTERCONNECTION

HV Junction Box Outer	HVJ-6322
HV Junction Box Inner	HVJ-6323
HV Deck Cable	HVC-6321-4001

Options:

- Option for cable drum exits on outer or internal face.
- Main body spacers to fit client winch to provide chassis support..
- Bespoke mounting plate options.
- HV connection cable lengths.

